

SP PUMP INTEGRAL VALVING OPTIONS

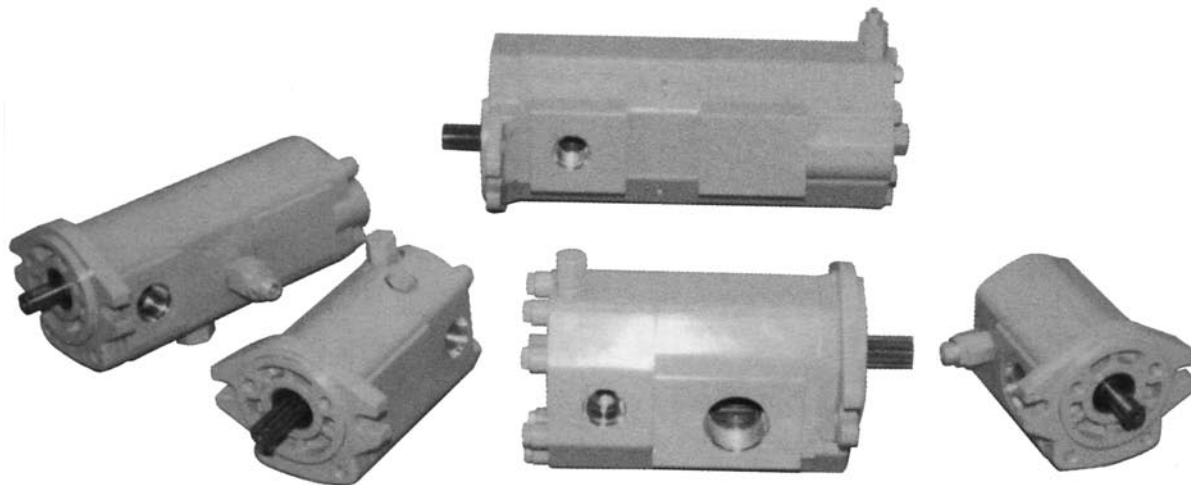

PRINCE SP PUMPS WITH INTEGRAL VALVING FEATURE EXTRUDED ALUMINUM REAR COVERS. THE EXTRUDED REAR COVERS ALLOW EXCEPTIONAL FLEXIBILITY FOR INCORPORATING DIFFERENT VALVING AND PORTING OPTIONS. PRINCE'S USE OF COMPUTER CONTROLLED MACHINING CENTERS IN THE MANUFACTURING PROCESS ALLOW EITHER STANDARD OR CUSTOM DESIGNS TO BE MADE IN BOTH SMALL AND LARGE QUANTITIES.

- **PRIORITY FLOW DIVIDER PUMPS**

Priority flow divider pumps split the flow between a priority port and an excess flow port. The flow is initially directed to the priority port until the priority setting is satisfied. At that time any additional flow is directed to the excess flow port. Priority divider pumps are typically used in steering circuits, brake circuits or any circuit where a primary flow needs to be satisfied first.

- **RELIEF VALVES**

Various styles and configurations of relief valves can be provided in the rear cover. The relief return flow can be either ported external to the pump or internally ported back to the inlet. Caution must be used so that the duration of the internally ported flow does not cause excessive heat build up.

- **CUSTOM DESIGN VALVE PACKAGES**

Prince Manufacturing offers custom designed integral valve packages. Configurations are developed based on customer specifications.

- **SOLENOID VALVES**

Various configurations of controlling pump flow by using solenoid cartridge valves are available.

- **SPECIAL REAR PORTING**

A wide variety of port types as well as port locations can be accommodated with the extruded rear cover.

- **DOUBLE PUMP CONFIGURATIONS**

Integral valve configurations can easily be integrated into double pump configurations. Valves in the rear cover typically control flow from the rear pump section, however valves can also be incorporated into the center section of the double pump for additional control options.

- **HIGH-LO PUMPS (Horse power limiting pumps)**

A high-lo configuration is available based on the SP20 series pump. The typical configuration provides 28 gpm low pressure flow and 7 gpm high pressure flow (at 3500 rpm). Typical horsepower requirements are 19 hp at 3000 psi and 3500 rpm.



PRINCE MANUFACTURING CORPORATION

P.O. BOX 7000
NORTH SIOUX CITY, SD 57049-7000
TELEPHONE: 605-235-1220
FAX: 605-235-1082

SP25P SERIES - PRIORITY FLOW DIVIDER PUMPS MODEL CODE

SP25P 52 J 185 H 2 R

SERIES NO. _____

DISPLACEMENT CODE (CC/REV) _____

PRIORITY FLOW + _____

G - 1.5 GPM PRIORITY FLOW
H - 2.0 GPM PRIORITY FLOW
J - 2.5 GPM PRIORITY FLOW
K - 3.0 GPM PRIORITY FLOW
L - 3.5 GPM PRIORITY FLOW
M - 4.0 GPM PRIORITY FLOW
N - 4.5 GPM PRIORITY FLOW
P - 5.0 GPM PRIORITY FLOW

PRIORITY FLOW RELIEF SETTING + _____

THE THREE DIGIT CODE REPRESENTS RELIEF VALVE SETTING DIVIDED BY 10. FOR INSTANCE A CODE NUMBER OF 185 REPRESENTS A FULL FLOW RELIEF SETTING OF 1850 PSI. (RELIEF SETTING MUST BE BETWEEN 1000 AND 2250 PSI.)

ROTATION (FACING END OF SHAFT)
L-COUNTERCLOCKWISE
R-CLOCKWISE

DRIVE SHAFT
1- SAE 13 TOOTH 16/32 SPLINE
2- SAE 7/8" STRAIGHT KEYED

MOUNTING
H- SAE "B" 2 BOLT

+ FOR PRIORITY FLOWS AND RELIEF SETTINGS NOT INDICATED, CONTACT FACTORY.

SP25P SERIES DIMENSIONAL DATA

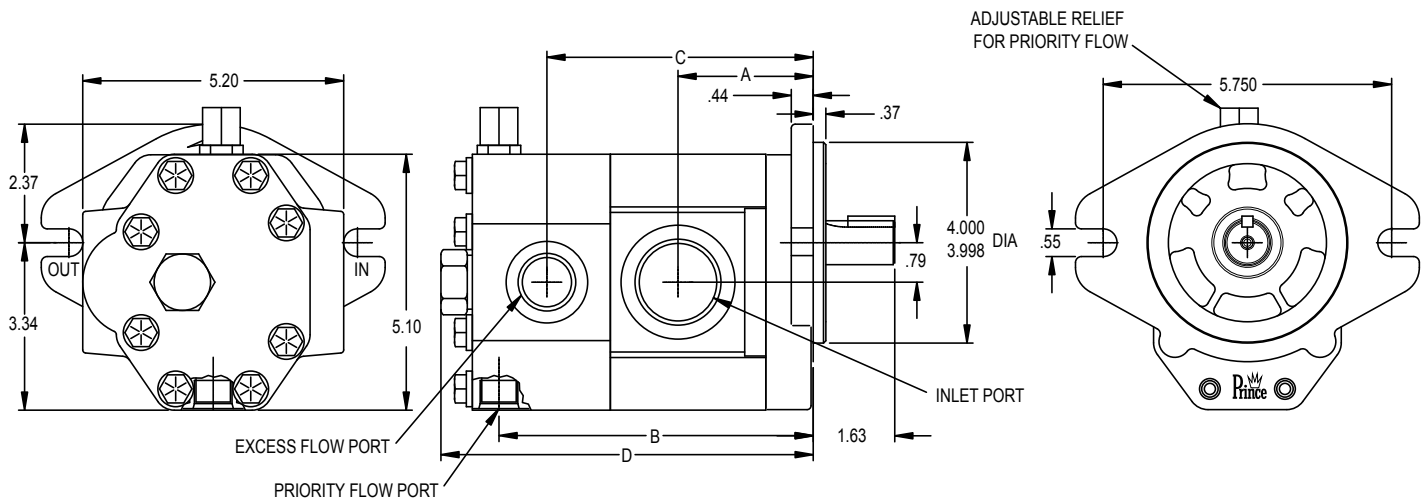

RIGHT HAND ROTATION SHOWN. FOR LEFT HAND ROTATION, INLET AND EXCESS FLOW PORTS GO TO THE OPPOSITE SIDE OF THE PUMP, PRIORITY FLOW PORT GOES FROM THE BOTTOM TO THE TOP OF THE PUMP.

SPECIFICATIONS

MODEL NUMBER	DISP. IN ³ /REV	RATED PRESSURE	MAX. RPM	A	B	C	D	INLET PORT SIZE		EXCESS FLOW PORT SIZE	PRIORITY FLOW PORT SIZE	WT. (LB.)
SP25P19	1.141	3000	3000	2.49	6.26	5.32	7.42	1 5/16-12 UN-2B	3/4" FULL THREAD DEPTH	1 1/16-12 UN-2B	3/4-16 UN-2B	14.7
SP25P22	1.349	3000	3000	2.55	6.38	5.44	7.54					14.9
SP25P27	1.660	3000	3000	2.64	6.56	5.62	7.71	15.3				
SP25P32	2.008	3000	3000	2.74	6.75	5.82	7.91	16.7				
SP25P38	2.318	3000	3000	2.83	6.93	5.99	8.09	17.8				
SP25P44	2.697	3000	3000	2.94	7.15	6.21	8.30	18.2				
SP25P52	3.179	2500	2500	3.07	7.42	6.49	8.58	1 5/8-12 UN-2B	3/4" FULL THREAD DEPTH	9/16" FULL THREAD DEPTH	18.7	
SP25P63	3.869	2500	2100	3.27	7.82	6.88	8.97	1 7/8-12			19.7	

FOR PUMP PERFORMANCE DATA AND SHAFT DIMENSIONAL DATA, REFER TO THE SP25A PUMP SECTION.
Standard Seal Kit for all SP25 Models is Prince Part No. PMCK-SP25.

PUMPS AND MOTORS