



**CHECKBALL PISTON PUMPS
PF1300 SERIES, 10 DESIGN**

PF13*-***-10**

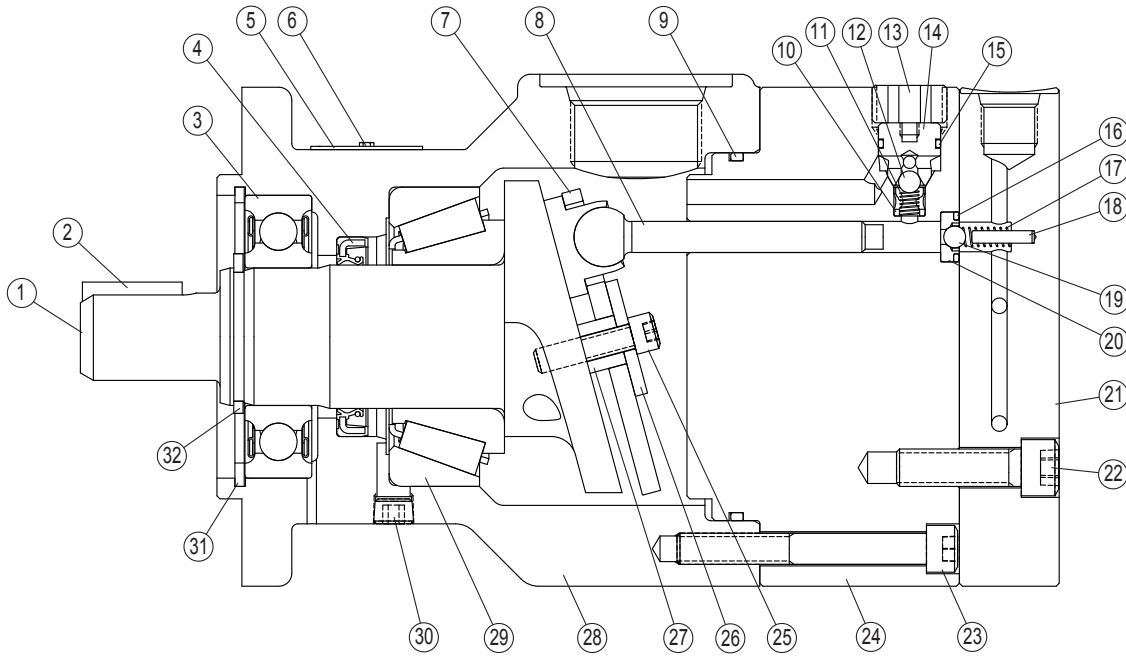

TABLE A – PARTS LIST

ID Number	Part Number	Part Description	Quantity Required
1	See Table B	Camshaft	1
2	1009.325	Key	0or1
3	1104.155	Shaft Bearing (Front)	1
4	See Kit Table C	Shaft Seal	1
5	1137.026	Nameplate	1
6	1001.003	Screw (Nameplate)	2
7	See Table B	Holdown Plate	1
8	3079.900	Piston Subassembly ^②	3or5
9	See Kit Table C	O-ring (Housing/Barrel)	1
10	1120.290	Inlet Checkball Stop ^{①⑦}	3or5
11	1305.110	Spring (Inlet) ^⑦	3or5
12	1081.016	Checkball (Inlet) ^⑦	3or5
13	1577.006	Hex Jam Screw ^{②⑦}	3or5
14	1119.290	Inlet Check Seat ^⑦	3or5
15	See Kit Table C	O-ring (Inlet Check Seat) ^⑦	3or5
16	See Kit Table C	O-ring (Outlet Check Seat) ^⑦	3or5
17	1306.110	Spring (Outlet) ^⑦	3or5
18	See Kit Table D	Pin ^⑧	3or5

ID Number	Part Number	Part Description	Quantity Required
19	1081.016	Checkball (Outlet) ^⑦	3or5
20	1121.290	Outlet Check Seat ^⑦	3or5
21	See Kit Table D	Cover Assembly Kit	1
22	1071.028	Socket-head Capscrew ^{③⑤}	5or6
23	1359.028	Socket-head Capscrew ^{④⑤}	5or6
24	See Table B	Barrel	1
25	1011.028	Screw ^⑥	1
26	1096.132	Spacer	1
27	1146.232	Spacer Sleeve	1
28	See Kit Table B	Housing	1
29	1108.155	Bearing	1
30	1007.245	Plug (Drain Port)	1
31	1169.049	Retaining Ring	1
32	1168.049	Retaining Ring	1

- ① Apply Loctite #680 or equivalent.
- ② Torque to 60 lb-ft (81 N-m).
- ③ Torque to 48 lb-ft (49 N-m).
- ④ Torque to 30 lb-ft (41 N-m).
- ⑤ Quantity 5 for for 5 piston models, 6 for 3 piston models. See Table D.
- ⑥ Apply Loctite #271 or equivalent. Torque to 160 lb-in (18 N-m).
- ⑦ Quantity equals number of pistons:
(PF1301- PF1308 = 3, PF1313 - PF1320 = 5)
- ⑧ Pin included in Cover Assembly Kit. See Table D.

TABLE B – OUTPUT FLOW, CAMSHAFT, HOLDDOWN, BARREL, HOUSING OPTIONS

Output Flow Code	Number of Pistons	Cam Shaft			Barrel	Housing
		Keyed	Spline	Holddown Plate		
01	3	1175.288	1179.288	1461.101	1235.050	1227.277
03	3	1188.288	1189.288	1461.101	1235.050	1227.277
05	3	1176.288	1180.288	1461.101	1235.050	1227.277
08	3	1177.288	1181.288	1461.101	1235.050	1227.277
13	5	1188.288	1189.288	1460.101	1234.050	1226.277
15	5	1176.288	1180.288	1460.101	1234.050	1226.277
18	5	1177.288	1181.288	1460.101	1234.050	1226.277
20	5	1178.288	1182.288	1460.101	1234.050	1226.277

TABLE C – SEAL KITS

Seal Code	Description	Kit Number
D	Standard: Buna-N (Nitrile) with Disogrin® (Polyurethane) o-rings in the cover	KP13009110
XD	Fluorocarbon (Viton® or Fluorel®) with Polyurethane (Disogrin®) o-rings in the cover and High Pressure Shaft Seal	KP13009018
XE	All EPR (Ethylene-Propylene Rubber) with High Pressure Shaft Seal	KP13009112
XV	All Fluorocarbon (Viton® or Fluorel®) with High Pressure Shaft Seal	KP13009111

TABLE D – PORT, COVER KITS

Port Code	Number of Pistons	Outlet Port Type	Cover Kit Number
No Code	3	No. 6 SAE	KP13039050
A	3	3/8 MP	KP13039051
B	3	G 1/4 BSPP	KP13039052
No Code	5	No. 6 SAE	KP13059050
A	5	3/8 MP	KP13059051
B	5	G 1/4 BSPP	KP13059052

TYPICAL MODEL CODE

PF13

01

H – S D

A

–

1

0

Pump Type	
PF13	Fixed Displacement Checkball Pump

Output Flow (At 1800 rpm, at Max. Pressure) ^①	
01	Standard: 0.31 (1,18 L/min) “H” Option: 0.30 gpm (1,14 L/min)
03	Standard: 0.43 (1,63 L/min) “H” Option: 0.42 gpm (1,58 L/min)
05	Standard: 0.55 (2,08 L/min) “H” Option: 0.54 gpm (2,03 L/min)
08	Standard: 0.73 (2,76 L/min) “H” Option: 0.72 gpm (2,73 L/min)
15	Standard: 0.91 (3,45 L/min) “H” Option: 0.89 gpm (3,37 L/min)
18	Standard: 1.21 (4,58 L/min) “H” Option: 1.20 gpm (4,54 L/min)
20	Standard: 1.42 (5,37 L/min)

① Output flows based on typical performance at maximum pressure. Refer to performance curves for flows at lower pressure.

② Models PF1301, PF1303, PF1305 and PF1308 have three pistons. Other models have five pistons.

Operating Pressure	
No Code	Standard Pressure
H	High Pressure ^①

① Requires “A” or “B” port option.

Ports	
No Code	Inlet No. 16 SAE; Outlet No. 6 SAE ^①
A	Inlet No. 16 SAE; Outlet 3/8 Medium Pressure Coned and Threaded, 0.5625-18 UNF-2B Threaded ^②
B	Inlet No. 16 SAE; Outlet G 1/4 (BSPP) ^③

① Not recommended for operation above 8000 psi (560 bar). Contact the fitting manufacturer for the pressure rating of the fitting.

② High pressure port uses Autoclave Medium Pressure, Butech M/P or equivalent fitting.

③ Outlet port uses British Standard Pipe Parallel fitting. Not recommended for operation above 10 000 psi (700 bar).

Design Number

Modification Number

Seals	
D	Standard: Buna-N (Nitrile) with Polyurethane (Disogrin [®]) o-rings in the cover
XD	Fluorocarbon (Viton [®] or Fluorel [®]) with Polyurethane (Disogrin [®]) o-rings in the cover and High Pressure Shaft Seal
XE	All EPR with High Pressure Shaft Seal ^①
XV	All Fluorocarbon (Viton [®] or Fluorel [®]) with High Pressure Shaft Seal

① Contact the Sales department for recommended operating conditions with EPR seals.

Drive Shaft	
No Code	Keyed, .875 inch (22,23 mm) diameter
S	SAE Spline, .875 inch (22,23 mm) diameter

www.dynexhydraulics.com

USA Headquarters

770 Capitol Drive
Pewaukee, WI 53072
Tel: 1-262-691-2222
FAX: 1-262-691-0312
E-mail: sales@dynexhydraulics.com

Power Units & Systems

54 Nickerson Road
Ashland, MA 01721
Tel: 1-508-881-5110
FAX: 1-508-881-6849
E-mail: sales@ashland.dynexhydraulics.com

European Sales

Unit C5 Steel Close, Little End Road,
Eaton Socon, St Neots,
Cambs. PE19 8TT United Kingdom
Tel:+44 (0) 1480 213980 FAX:+44 (0) 1480 405662
E-mail: sales@dynexhydraulics.co.uk