

Checkball Piston Pumps For Water-Based Fluids

Fixed displacement checkball pumps are compatible with a variety of water-based and other low-lubricity fluids. Bi-directional shaft rotation provides constant direction of output flow regardless of drive shaft rotation.

MAINTENANCE-FREE DESIGN

The single-fluid checkball design uses the pumped fluid for internal bearing lubrication. This eliminates the potential for fluid cross-contamination, possible in other designs with isolated lubrication. It also avoids the cost of a lubrication circuit.

RELIABLE HIGH PRESSURE

Individual piston check valves provide long service life and greater volumetric efficiency, especially at high pressures and with low-lubricity fluids.

The check valves take the place of a valveplate in other pump designs. With no rotating sealing surface, checkball pumps are resistant to wearing and scoring.

TYPICAL APPLICATIONS

These pumps are ideal for use in wellhead safety control systems and other subsea applications, providing long life operating at high pressures with water-based fluids. These pumps are ATEX compliant.

They are also used on hydroform presses, and other applications requiring environmentally-friendly or fire-resistant fluids.

These pump options are a variant of the PF4312H-XVB-12 or 20. These pump designs incorporate a different piston assembly that allows for operation in applications that can't provide an optimal inlet condition.

Due to the different piston construction, these pumps do not require a super-charge compared to the standard PF4312 Products. (See Minimum Inlet Pressure Guidelines)

PF4312 SERIES – J1115 Split-Flow
PF4312 SERIES – J1239 Split-Flow
8.2 gpm (31,0 L/min) at 1800 rpm
8000 psi (560 bar)



Specifications

Pump Models	Output Flow at 1200 rpm ^①		Output Flow at 1500 rpm ^{①②}		Output Flow at 1800 rpm ^{①②}		Maximum Pressure		Min. Speed rpm ^②	Maximum Speed rpm ^②
	U.S. gpm	L/min	U.S. gpm	L/min	U.S. gpm	L/min	psi	bar		
PF4312	5.5	20,7	6.8	25,9	8.2	31,0	8000	560	900	1800

^① Output flow based on typical performance using 33 SUS (1,9 cSt) water glycol fluid at maximum pressure with pressurized inlet where required. Refer to the "Minimum Inlet Pressure" table on page 2.

^② Contact the sales department for operation below 900 rpm.

The limitation of this design is in maximum pressure which is reduced from 10000 psi (700 bar) to 8000 psi (560 bar).

PUMP SELECTION

PF4312-12 – J1115: Carbon Steel Model
 PF4312-20 – J1239: Stainless Steel Model

INSTALLATION AND OPERATING

Refer to separate Bulletin PSI.CB for general installation and operating recommendations.

All dimensions are shown in inches (millimeters in parentheses) and are nominal.

Mounting

S.A.E. D 4-bolt pattern with 0.25 inch (6,4 mm) pilot engagement.

Shaft

Standard keyed shaft, 1.250 inch (31,75 mm) diameter;

Outlet Port

British Standard Pipe fitting.

As shown, the outlet port on these pumps is machined in a block integrally mounted to the pump barrel. See information below for reference.

Orientation/Drive

Shaft horizontal with inlet vertically up is preferred. Vertical shaft mounting is possible, but requires connecting a line to the bleed port in the pump housing. Contact the sales department for more information.

Seals

Fluorocarbon (Viton® or Fluorel®).

Minimum Filtration Levels

Pump inlet: 150 μ nominal;
Pressure or return line: 25 μ nominal.

While finer filtration levels than these are desirable and will result in longer component life, restricting flow to the pump inlet should be avoided. Minimum recommended inlet conditions must be maintained.

Weight (Mass)

116 lb (53 kg)

Minimum Inlet Pressure^①

IMPORTANT: Pumps may require pressurized inlet conditions at higher speeds. Failure to meet minimum inlet requirements will result in flow reduction. Refer to the table.

Pump Models	Operating Speed					
	1200 rpm		1500 rpm		1800 rpm	
	psi	bar	psi	bar	psi	bar
PF4312	0	0	0	0	3	.2

^① Values shown are based on fluid viscosity of 33 SUS (1,9 cSt).

Hydraulic Fluid Viscosity Guidelines^①

Operating					
Minimum		Maximum		Start-up	
SUS	cSt	SUS	cSt	SUS	cSt
32	1,5	927	200	927	200

^① If fluid conditions fall outside of the range shown, contact the sales department.

FLUID RECOMMENDATIONS

Special Fluid Operation

Because of the wide range of water-based fluid characteristics, contact the sales department for a review of the application requiring non-petroleum based fluid.

Viscosity Specifications

Using fluid with the correct viscosity range is critical to achieving long component life.

Fluid conditions outside the ranges shown in the table may result in reduced pump output, requiring pressurized inlet conditions. For more information, contact the sales department.

Typical Performance Curves^①

IMPORTANT: Typical performance curves are based on 33 SUS (1,9 cSt) water glycol fluid. Pumps may require pressurized inlet conditions at higher speeds. Failure to meet minimum inlet requirements will result in flow reduction. Refer to the table above.

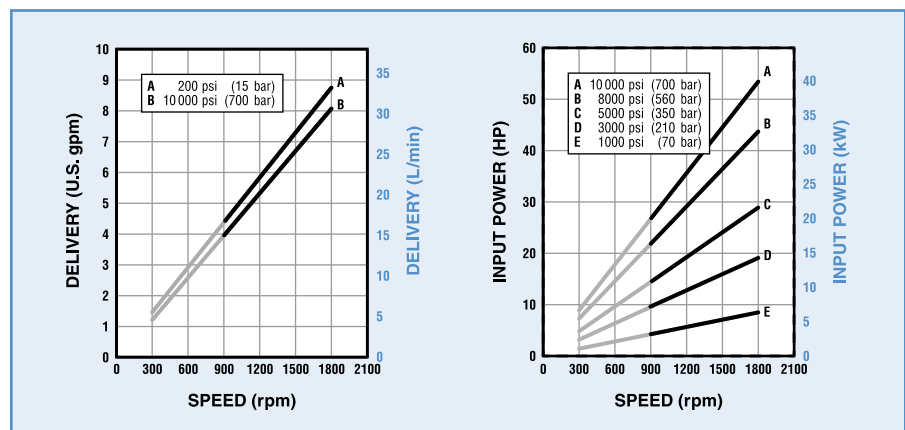

^① Contact the sales department for operation below 900 rpm.

FLUID RECOMMENDATIONS (All Checkball Pumps)

Mineral Oil

A high-grade premium petroleum-based fluid should be used to assure long component and system life. The fluid should have a combination of anti-wear, demulsibility, rust protection, oxidation-resistant and foam-resistant properties.

Special Fluids

Various pump models are available for use with water-based fluids, diesel calibration fluids, phosphate ester fluids, machining coolant, brake fluid, various military fluids and other special fluids.

PF1300 & PF4300 Series pumps are compatible with a variety of water-based fluids. Refer to specific product documentation for specifications for these models, which are specifically rated for use with low-lubricity fluids.

Some pump models may require reduced operating pressures when using low-lubricity fluids.

Because of the wide range of fluid characteristics, contact the sales department for a review of any application using non-petroleum based fluids.

Viscosity Specifications

Using fluid with the correct viscosity range is critical to achieving long component life.

Fluid conditions outside the "Optimum" range shown in the table may result in reduced pump output, requiring pressurized inlet conditions. For more information, contact the sales department.

Hydraulic Fluid Viscosity^①

Pump Models	Operating				Start-up ^②		Optimum		
	Minimum		Maximum		SUS	cSt	SUS	cSt	
	SUS	cSt	SUS	cSt					
<i>Fixed Displacement Pumps:</i>									
PF500-10	52	8	1911	413	3706	800	98 to 324	20 to 70	
PF1000-10	59	10	1911	413	3706	800	98 to 324	20 to 70	
PF1300-10	31	1,3	927	200	927	200	–	–	
PF2000	59	10	1911	413	1911	413	98 to 324	20 to 70	
PF2000 ^②	34	2,3	1911	413	1911	413	98 to 324	20 to 70	
PF3000-10	59	10	1911	413	3706	800	98 to 342	20 to 70	
PF4000-30	34	2,3	1911	413	1911	413	98 to 324	20 to 70	
PF4200-10	34	2,3	1911	413	1911	413	98 to 324	20 to 70	
PF4300-20	31	1,3	927	200	927	200	–	–	
PF6000	34	2,3	1911	413	1911	413	98 to 324	20 to 70	
<i>Mechanical Variable Delivery Pumps:</i>									
PV4000	34	2,3	1911	413	1911	413	98 to 324	20 to 70	
PV6000	34	2,3	1911	413	1911	413	98 to 324	20 to 70	
<i>Hydraulic Variable Delivery Pumps:</i>									
PV6000	34	2,3	1911	413	1911	413	98 to 324	20 to 70	

① Fluid conditions outside the "Optimum" range may result in reduced output, requiring pressurized inlet conditions. Contact the sales department.

② Models with special mounting.

MINIMUM FILTRATION LEVELS

Pump inlet: 150 μ nominal;

Pressure or return line: 25 μ nominal.

While finer filtration levels than these are desirable and will result in longer component life, restricting flow to the pump inlet should be avoided. Minimum recommended inlet conditions must be maintained.

If a system component fails resulting in fluid contamination, it is important to drain and clean the reservoir, all lines, filter screens and all components. Refill with new fluid.

INSTALLATION AND OPERATION

Refer to separate Bulletin: *Checkball Pumps Service, Installation and Operating Instructions* for general installation and operating recommendations.

That brochure includes information on mounting, shaft loading, sizing inlet pipe and hose, air bleed procedures and initial start-up. Guidelines for maintenance, repair and trouble-shooting are also included.

OULET PORT CONFIGURATIONS

Dynex pumps are available with outlet ports suitable for use at various pressure ranges. Refer to the appropriate "Specification Table" or "Typical Model Code" to specify the required port.

Contact the fitting manufacturer to ensure the selected fittings are rated for the maximum pump operating pressure.

S.A.E. Straight Thread Ports

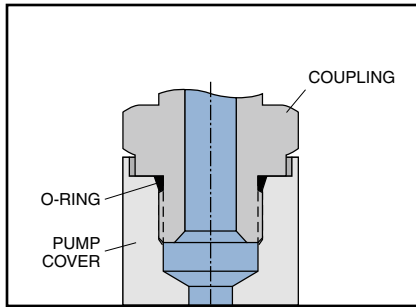

Typical S.A.E. Straight Thread port connection

The Straight Thread connection (S.A.E. J1926/1) is sometimes referred to as an S.A.E. O-ring Boss, or ORB. The port consists of a machined spotface surface, a tapered seal cavity and a straight thread port.

The fitting forms a seal by compressing the o-ring in the seal cavity with the underside of the flanged wrench flat. Some adjustable fittings, such as elbows and tees, use a locknut with a captive backup washer for compression.

S.A.E. Straight Thread ports are not recommended for operation above 8000 psi (560 bar). Also, the maximum pressure of pumps with No. 12 S.A.E. outlet ports may be limited by the pressure rating of the available fitting. Contact the fitting manufacturer for ratings.

Coned and Threaded Ports

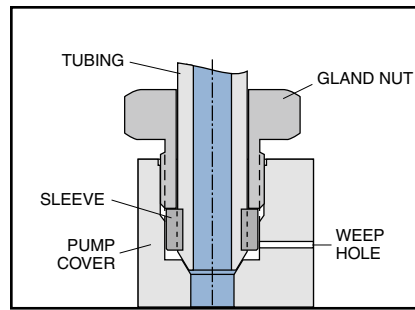

Typical Coned and Threaded port connection

High-pressure pumps are available with coned and threaded outlet ports, which use Autoclave Medium Pressure, Butech M/P, or equivalent fittings.

These fittings provide a metal-to-metal seal with an interference fit, not requiring an o-ring. The gland nut holds the sleeve and tubing against the cone surface.

A weep hole, visible on the outside of the pump cover, acts as an indicator of any abnormal leakage caused by system conditions (i.e., excessive pressure). It allows any fluid which does leak past the sealing surfaces to escape, preventing pressure build-up and possible damage.

British Standard Pipe Ports

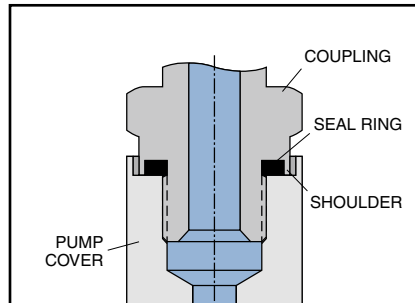

Typical port connection with British Standard Pipe (Parallel) fitting with shoulder

High-pressure pumps are available with flat face ports with British Standard Pipe (B.S.P.) parallel threads (BS 2779 or ISO 228), ideal for use on some European applications.

The fitting forms a seal by compressing a flat elastomer ring on a machined spotface surface. There are several sealing methods for these ports.

The recommended fitting has a recessed seal cavity formed by a shoulder on the underside of the flanged wrench flat (Voss "Peflex", Form B Shoulder Seal; or Parker Type E, "EOlastic" Seal; or equivalent).

B.S.P. ports are not recommended for operation above 10 000 psi (700 bar). Contact the fitting manufacturer, to ensure the selected fittings are rated for the maximum pump operating pressure.

S.A.E. 4-Bolt Flange Ports

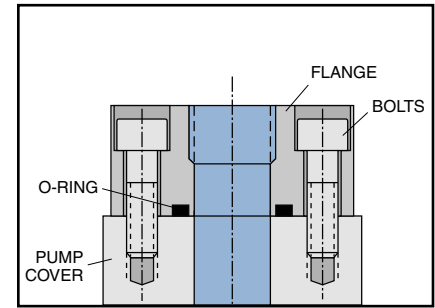

Typical S.A.E. 4-Bolt Flange port connection

Flange connections are often used for higher flows requiring larger diameter tubing. The port consists of an unthreaded port with four bolt holes in a rectangular pattern on a machined face around the port (S.A.E. J518).

A typical fitting consists of a flanged head with a welded tube and a captive flange with bolt holes. A seal is formed by an o-ring in the groove on the underside mounting surface of the flange head. As the flange bolts are alternately tightened, the o-ring is compressed between the flange head and the machined face on the pump.

To make mounting easier in tight spaces a two-piece split-flange is often used.